



A Cavagna Group Company

PRESSURE REGULATORS **S22**

SPRING LOADED



1 DESCRIPTION

The regulator **S22** is a downstream direct-acting pressure regulator with balanced plug, for low, medium and high pressures.

Suitable for civil and industrial uses in canalized networks for natural gas, manufactured gas, LPG and non-corrosive liquids.

Thanks to the concept of a balanced system, the following features are achieved:

- high and accurate flow rate coefficient (even at maximum flow rates);
- high accuracy for lock up zone and pressure.
- Full lock up – no internal leakage.
- Reduced response times.

The **S22** pressure regulator is classified “Fail to Open” type, according to European Standard EN 334.

The **S22** pressure regulators are “top entry” type, which allows for maintenance operations without having to remove the body from the pipes.

2 AVAILABLE VERSIONS

.BP

for an inlet pressure range of 0,5 ÷ 5 bar
for an outlet pressure range of 10 ÷ 150 mbar

.MP

for an inlet pressure range of 0,5 ÷ 5 bar
for an outlet pressure range of 150 ÷ 500 mbar

.AP

for an inlet pressure range of 0,5 ÷ 5 bar
for an outlet pressure range of 500 ÷ 4000 mbar

.APA

for an inlet pressure range of 2 ÷ 20 bar
for an outlet pressure range of 500 ÷ 4000 mbar

3 MATERIALS

- Body in cast iron (GJS-400-18 UNI EN 1563)
- Covers in aluminium die-cast EN AC46100 EN1706
- Diaphragms in rubber with cloth enforcement
- Seats in stainless steel or brass
- Springs in stainless steel

4 FEATURES

- Anti-pumping device
- Diaphragm shock absorber or relief valve
- In accordance to 2014/68/UE - EN334
- Working Temperature: -20° C (-30°C) ÷ 60°C
- Regulating Class: up to A.C. 5
- Closing Pressure Class: up to S.G. 10

5 TECHNICAL DATA

- AVAILABLE VERSIONS:**
- **B:** WITH OPSO/UPS0 SHUT-OFF VALVE
 - **M:** WORKING AS MONITOR

	INLET PRESSURE		OUTLET PRESSURE			CG (VALVE COEFFICIENT)	CONNECTIONS
	BP, MP, AP	APA	BP	MP	AP, APA		
	BAR						
S22- IPR 300	5 or 6	20	14 ÷ 150	150 ÷ 500	500 ÷ 4000	574	DN40
S22- IPR 600	5 or 6	20			500 ÷ 4000	1160	DN50

5.1 DIMENSIONING

The choice of the regulator is made using the **CG** valve coefficient.

CG coefficient is numerically equivalent to the value of air flow in Scfh in critical conditions with full open regulator operating with an upstream pressure of 1 psia and a temperature of 15° C.

Flow rates with maximum operating at different operating conditions can be calculated as follows:

a. in non critical conditions (when $P_u < 2 P_d$)

$$Q = \frac{13,57}{\sqrt{d \times (t_u + 273)}} \times C_g \times \frac{p_u + p_b}{2} \times \sin \left[K_1 \times \sqrt{\frac{p_u - p_d}{p_u + p_b}} \right]_{deg}$$

b. in critical conditions (when $P_u \geq 2 P_d$)

$$Q = \frac{13,57}{\sqrt{d \times (t_u + 273)}} \times C_g \times \frac{p_u + p_d}{2}$$

where:

Q = capacity [Stm³/h]

P_u = Absolute upstream pressure [bar]

P_d = Absolute downstream pressure

P_b = Ambient atmospheric pressure [bar]

d = relative density (air= 1, non dimensional value)

K_1 = body shape factor

t_u = gas temperature at the inlet of the regulator under test in °C

6 OPERATING PRINCIPLE

The operating principle for the **S22** regulators is the same as for all models, with the exception of certain marginal differences, exemplified below.

The **S22** pressure regulator is a direct action type instrument with pressure control downstream through external impulse **(A)**.

The downstream pressure is controlled by comparing the spring load **(B)** and the thrust deriving from the downstream pressure on the diaphragm **(C)**.

The diaphragm's movement is transmitted by the lever system **(D)** to the rod **(E)** and stopper **(F)**. The rubber pad **(G)** is vulcanized on the stopper and assures hermetic closing when the required capacity is nil.

If during operation the thrust deriving from the downstream pressure is less than the spring load **(B)**, the diaphragm **(C)** lower itself, and draws the stopper **(F)** away from the valve housing **(H)** until the downstream pressure once again attains the pre-set calibration value.

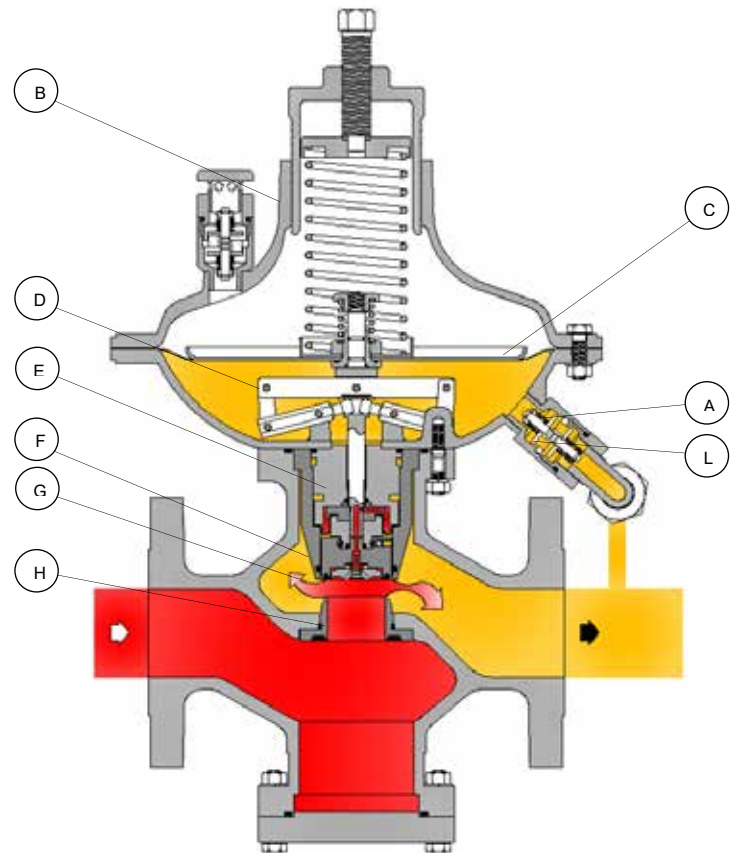

7.1 OVERALL DIMENSIONS

S22-IPR 300 B / S22-IPR 600 B

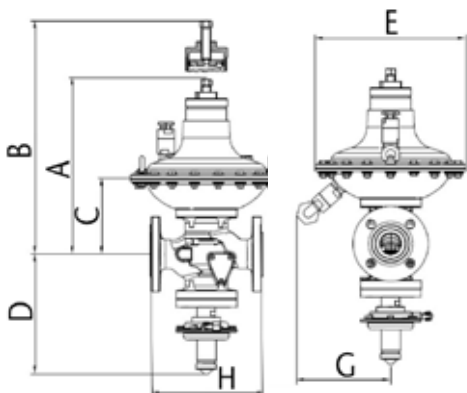

	H		A	B	C	D	F	G	E		
	DN 40	DN 50							VERSION		
	mm										
S22-IPR 300 B	223		400	460	151	240		175	300	300	300 TR
									BP	MP	AP - APA
S22-IPR 600 B	223	254	400	460	165	250		175	300	300	300 TR
									BP	MP	AP - APA

7.2 INSTALLATION S22

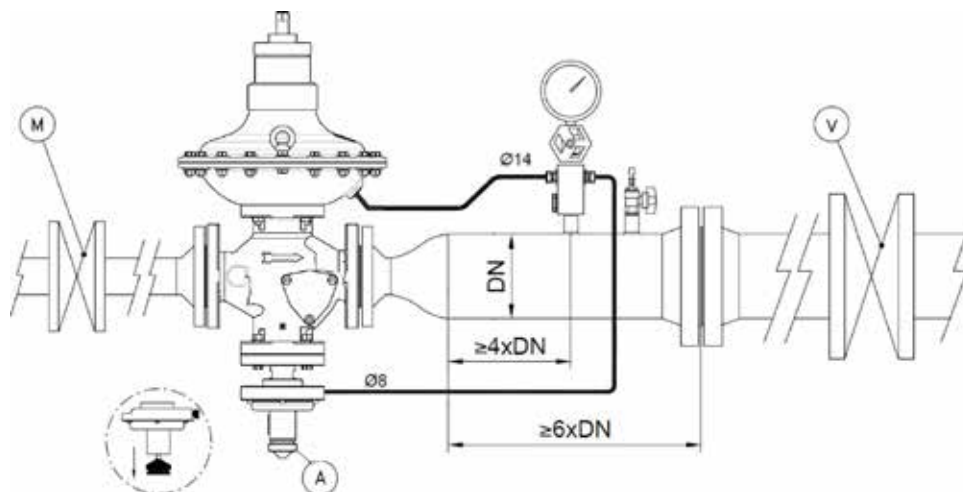

Mesura S.A.S.
TECHNOPOLE FORBACH SUD
 Rue Robert BUNSEN - CS 50102 - 57602 FORBACH CEDEX - France
www.mesura.fr

Cavagna Group Division RECA
 via Matteotti 5 - 25012 - Viadana di Calvisano (BS) - Italy
 Tel : +39 030 9688611
info@cavagnagroup.com
www.cavagnagroup.com



A Cavagna Group Company